

RE.C6-G

Injected polyurethan twin wheels for the general public

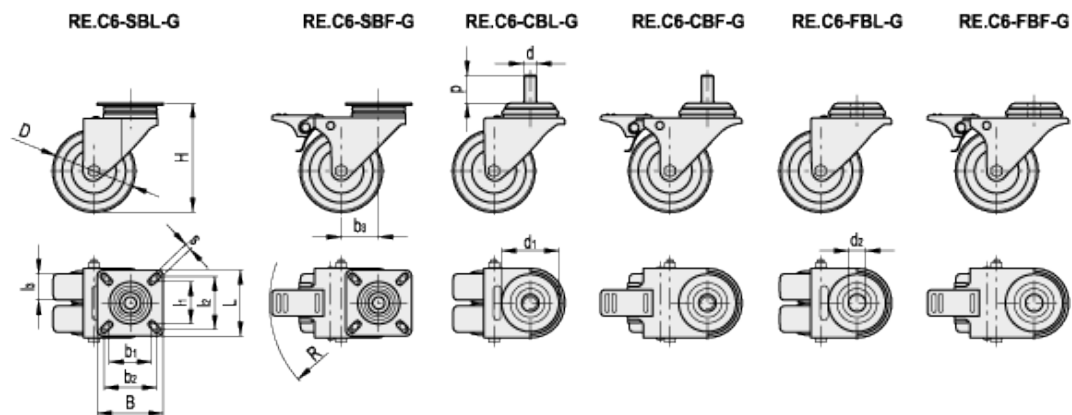

technical informations

Covering

Injected polyurethan, hardness 55 Shore D.

Wheel centre body

Polyamide-based technopolymer (PA). Resistant to solvents, oils and other chemicals.

Bore

Directly made into the centre.

Axle set

Calibrated zinc-plated steel precision tube. The tube serves as a spacer, is tightened to the bracket with screw and nut to a predetermined torque value. The wheel bore rotates onto the tube freely.

Turning plate bracket

Electrolytically zinc-plated steel sheet bracket.

The presence of two ball turns and the direct contact between the plate and the ball race ring with built-in pin ensure excellent manoeuvrability and very limited clearance.

Front-actuated brake

Total brake that locks the wheel and bracket rotation. The optimised dimensions and the retractable pedal ensure minimal space occupied and maximum actuation ease.

Standard executions

- SBL-G: turning plate bracket, without brake.
- SBF-G: turning plate bracket, with brake.
- CBL-G: turning plate bracket and threaded centre pin, without brake.
- CBF-G: turning plate bracket and threaded centre pin, with brake.
- FBL-G: turning plate bracket and centre pass-through hole, without brake.
- FBF-G: turning plate bracket and pass-through hole, with brake.

Applications

Wheels for the general public with high carrying capacity, excellent smoothness and elasticity features, good wear and tearing resistance.

Environmental conditions

RE.C6 twin wheels are suitable for use in industrial and institutional environments, even in the presence of moisture and chemical agents.

The good resistance to frequent cleaning cycles makes it suitable for environments where it is necessary to ensure hygiene.



Standard Elements		Main dimensions														Dynamic carrying capacity #	Weight		
Code	Description	D	l ₃	H	B	L	s	b ₁	l ₁	b ₂	l ₂	b ₃	R	d	p	d ₁	d ₂	[N]	g
451929	RE.C6-050-SBL-G	50	18	71	60	60	6	39	39	49	49	25.5	-	-	-	-	-	1400	300
451939	RE.C6-050-SBF-G	50	18	71	60	60	6	39	39	49	49	25.5	83	-	-	-	-	1400	350
451959	RE.C6-050-CBL-G	50	18	71	-	-	-	-	-	-	-	25.5	-	M10	25	52	-	1400	310
451969	RE.C6-050-CBF-G	50	18	71	-	-	-	-	-	-	-	25.5	83	M10	25	52	-	1400	360
451979	RE.C6-050-FBL-G	50	18	71	-	-	-	-	-	-	-	25.5	-	-	-	55	10	1400	270
451989	RE.C6-050-FBF-G	50	18	71	-	-	-	-	-	-	-	25.5	83	-	-	55	10	1400	320

See [Technical Data](#) for dynamic carrying capacity.

ELESA and GANTER models all rights reserved in accordance with the law. Always mention the source when reproducing our drawings.

STANDARD MACHINE ELEMENTS WORLDWIDE