

Levelling elements

Technopolymer base, steel stem

BASE

Glass-fibre reinforced polyamide based (PA) technopolymer, black colour, matte finish.

ARTICULATED STEM

Threaded zinc-plated steel with adjusting hexagon.

STANDARD EXECUTIONS

- **LSX.A**: without no-slip disk.
- **LSX.A-AS**: with SBR rubber no-slip disk, assembled to the base.

FEATURES

The static load values in the table below refer to the resistance to a load applied on the axis of the levelling element.

Under common working conditions, any lateral or angular stress that may affect the no-slip disk resistance must also be taken into consideration.

Under particularly severe working conditions or on adherent surfaces the LSX.A-AS execution with SBR rubber no-slip disk may not be optimal. In these cases see also LS.A-AS (see page).

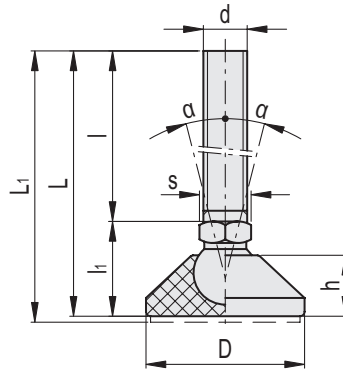

Code	Description	Code	Description	D	d	L	Li#	l	li	h	s	α	Articulation Ø	Max. limit static load* [N]	⚖️	⚖️ #
431521	LSX.A-26-10-M8x30	531521	LSX.A-26-10-AS-M8x30	26	M8	47	48	30	17	10	12	19°	10	4000	21	22
431523	LSX.A-26-10-M8x45	531523	LSX.A-26-10-AS-M8x45	26	M8	62	63	45	17	10	12	19°	10	4000	26	27
431525	LSX.A-26-10-M8x60	531525	LSX.A-26-10-AS-M8x60	26	M8	77	78	60	17	10	12	19°	10	4000	30	31
431531	LSX.A-26-10-M10x45	531531	LSX.A-26-10-AS-M10x45	26	M10	62	63	45	17	10	12	19°	10	4000	34	35
431533	LSX.A-26-10-M10x60	531533	LSX.A-26-10-AS-M10x60	26	M10	77	78	60	17	10	12	19°	10	4000	41	42
431535	LSX.A-26-10-M10x70	531535	LSX.A-26-10-AS-M10x70	26	M10	87	88	70	17	10	12	19°	10	4000	46	47
431537	LSX.A-26-10-M10x100	531537	LSX.A-26-10-AS-M10x100	26	M10	117	118	100	17	10	12	19°	10	4000	60	61
431541	LSX.A-30-10-M8x30	531541	LSX.A-30-10-AS-M8x30	30	M8	49	50	30	19	12	12	19°	10	4500	23	24
431543	LSX.A-30-10-M8x45	531543	LSX.A-30-10-AS-M8x45	30	M8	64	65	45	19	12	12	19°	10	4500	28	29
431545	LSX.A-30-10-M8x60	531545	LSX.A-30-10-AS-M8x60	30	M8	79	80	60	19	12	12	19°	10	4500	32	33
431551	LSX.A-30-10-M10x45	531551	LSX.A-30-10-AS-M10x45	30	M10	64	65	45	19	12	12	19°	10	4500	36	37
431553	LSX.A-30-10-M10x60	531553	LSX.A-30-10-AS-M10x60	30	M10	79	80	60	19	12	12	19°	10	4500	43	44
431555	LSX.A-30-10-M10x70	531555	LSX.A-30-10-AS-M10x70	30	M10	89	90	70	19	12	12	19°	10	4500	48	49
431557	LSX.A-30-10-M10x100	531557	LSX.A-30-10-AS-M10x100	30	M10	119	120	100	19	12	12	19°	10	4500	62	63
431561	LSX.A-40-10-M8x30	531561	LSX.A-40-10-AS-M8x30	40	M8	48.5	49.5	30	18.5	11.5	12	20°	10	5000	27	28
431563	LSX.A-40-10-M8x45	531563	LSX.A-40-10-AS-M8x45	40	M8	63.5	64.5	45	18.5	11.5	12	20°	10	5000	32	33
431565	LSX.A-40-10-M8x60	531565	LSX.A-40-10-AS-M8x60	40	M8	78.5	79.5	60	18.5	11.5	12	20°	10	5000	37	37
431571	LSX.A-40-10-M10x45	531571	LSX.A-40-10-AS-M10x45	40	M10	63.5	64.5	45	18.5	11.5	12	20°	10	5000	40	41
431573	LSX.A-40-10-M10x60	531573	LSX.A-40-10-AS-M10x60	40	M10	78.5	79.5	60	18.5	11.5	12	20°	10	5000	47	49
431575	LSX.A-40-10-M10x70	531575	LSX.A-40-10-AS-M10x70	40	M10	88.5	89.5	70	18.5	11.5	12	20°	10	5000	52	54
431577	LSX.A-40-10-M10x100	531577	LSX.A-40-10-AS-M10x100	40	M10	118.5	119.5	100	18.5	11.5	12	20°	10	5000	66	67

* The max static load is the value above which the load applied to the element may cause some plastic material breakage, in particular conditions of use. Obviously, a factor that takes into consideration the importance and the safety level of the specific application must be applied to this value.

Data with no-slip disk mounted.