

Spring Plungers

Steel / Stainless Steel, without Thread, with Collar

SPECIFICATION

Types

- Type **K**: Steel, standard spring load
- Type **KN**: Stainless steel, standard spring load

Type K

Housing

Steel, blackened

Bolt

Steel, blackened

Case hardened

Type KN

Housing

Stainless steel AISI 303

Bolt

Stainless steel AISI 303

Nitrided

Pressure spring

Stainless steel AISI 631



INFORMATION

Spring plungers GN 614.6 are primarily used in toolmaking as spring-loaded stops as well as for pressure and hold-off functions. Tolerance d_1 H7 is recommended for the mounting hole.

TECHNICAL INFORMATION

- ISO Fundamental Tolerances (see page A21)
- Stainless Steel Characteristics (see page A26)

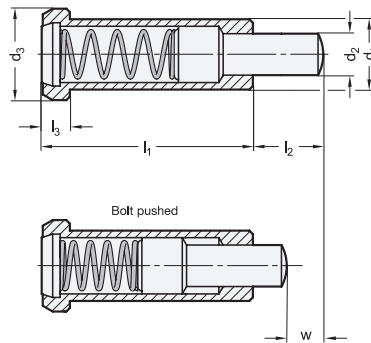

GN 614.6-K

Description	$d_1 -0.05$	d_2	d_3	l_1	l_2	l_3	w	Spring load in N \approx initial	Spring load in N \approx end	
GN 614.6-6-K	6	2.7	8	20	6	3.2	3.5	10	22	4
GN 614.6-8-K	8	3.9	10	24	8	3.2	4.5	30	88	8
GN 614.6-10-K	10	5.9	13	30	10	4	5.5	42	110	16
GN 614.6-12-K	12	7.9	16	36	12	5	6.5	50	130	27

GN 614.6-KN

STAINLESS STEEL

Description	$d_1 -0.05$	d_2	d_3	l_1	l_2	l_3	w	Spring load in N \approx initial	Spring load in N \approx end	
GN 614.6-6-KN	6	2.7	8	20	6	3.2	3.5	10	22	4
GN 614.6-8-KN	8	3.9	10	24	8	3.2	4.5	30	88	8
GN 614.6-10-KN	10	5.9	13	30	10	4	5.5	42	110	16
GN 614.6-12-KN	12	7.9	16	36	12	5	6.5	50	130	27